



# AH215

## 1 Watt, High Gain HBT Amplifier

The Communications Edge™

Preliminary Product Information

### Product Features

- 400 – 2300 MHz
- +31 dBm P1dB
- +46 dBm Output IP3
- 17 dB Gain @ 900 MHz
- Single Positive Supply (+5 V)
- SOIC-8 SMT Package

### Product Description

The AH215 is a high dynamic range driver amplifier in a low-cost surface mount package. The InGaP/GaAs HBT is able to achieve superior performance over a broad frequency range with +46 dBm OIP3 and +31 dBm of compressed 1-dB power. The part is housed in an industry standard SOIC-8 SMT package. All devices are 100% RF and dc tested.

The product is targeted for use as driver amplifier for various current and next generation wireless technologies such as GPRS, GSM, CDMA, W-CDMA, and UMTS, where high linearity and high power is required. The internal active bias allows the AH215 to maintain high linearity over temperature and operate directly off a +5 V supply.

### Functional Diagram

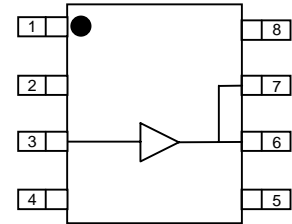

Function	Pin No.
Vref	1
Input	3
Output	6, 7
Vbias	8
GND	Slug
N/C or GND	2, 4, 5

### Target Specifications

Parameters	Units	Min	Typ	Max
Frequency Range	MHz	400	2140	2300
S21 - Gain	dB	10	11.5	
S11 - Input R.L.	dB		-15	
S22 - Output R.L.	dB		-10	
Output P1dB	dBm		+31	
Output IP3 <sup>2</sup>	dBm		+46	
Noise Figure	dB		6.0	
IS-95 Channel Power	dBm		+21	
@ -60 dBc ACPR, 9 Ch. Fwd., 1960 MHz				
W-CDMA Channel Power	dBm		+20	
@ -55 dBc, 2140MHz				
Operating Current Range	mA	400	450	500
Device Voltage	V		5	

Test conditions unless otherwise noted.

1. T = 25°C, Vsupply = +5 V, Frequency = 2140 MHz, in recommended application circuit.
2. 3OIP measured with two tones at an output power of +15 dBm/tone separated by 1 MHz. The suppression on the largest IM3 product is used to calculate the 3OIP using a 2:1 rule.

### Typical Specifications

Parameters	Units	Typical		
Frequency	MHz	880	1960	2140
S21 - Gain	dB	17	12	11.5
S11 - Input R.L.	dB	-10	-10	-15
S22 - Output R.L.	dB	-10	-10	-10
Output P1dB	dBm	+31	+31	31
Output IP3 <sup>2</sup>	dBm	+45	+46	46
Noise Figure	dB	6.0	6.0	6.0
Supply Bias		+5 V @ 450 mA		

Typical parameters reflect performance in recommended application circuit:  
Supply Voltage = +5 V, I = 450 mA, +25° C

### Absolute Maximum Rating

Parameters	Rating
RF Input Power (continuous)	+26 dBm
dc Voltage	+8 V
dc Power	5 W

Operation of this device above any of these parameters may cause permanent damage.

### Ordering Information

Part No.	Description
AH215	1 Watt, High Linearity HBT Amplifier (Available in Tape & Reel)
AH215-PCB1960	

This document contains information on a new product.  
Specifications and information are subject to change without notice.



# AH215

1 Watt, High Gain HBT Amplifier

The Communications Edge™

Preliminary Product Information

## 1960 MHz Application Circuit

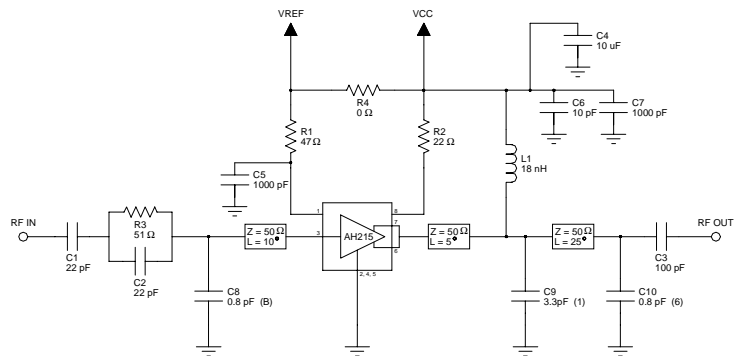
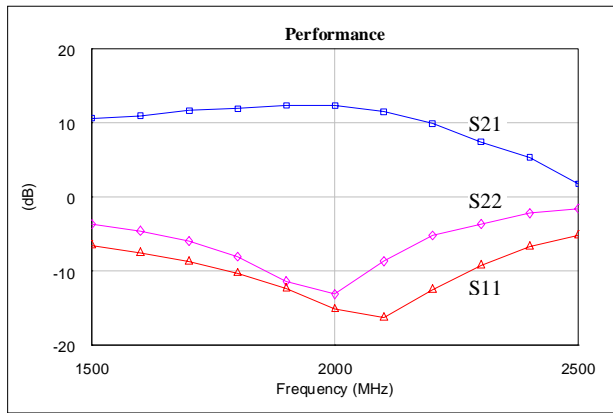

Typical Performance

Frequency	1960 MHz
S21 - Gain	12 dB
S11	-10 dB
S22	-10 dB
Output P1dB	31 dBm
Output IP3	46 dBm
Bias	5V, 450 mA

### NOTES:

Install R4 for single supply voltage control.. Remove R4 to adjust bias using V<sub>REF</sub> OR adjust bias by changing R1. Align C8 at point B, C9 at point 1 and C10 at point 6.

## Application Circuit PC Board Layout

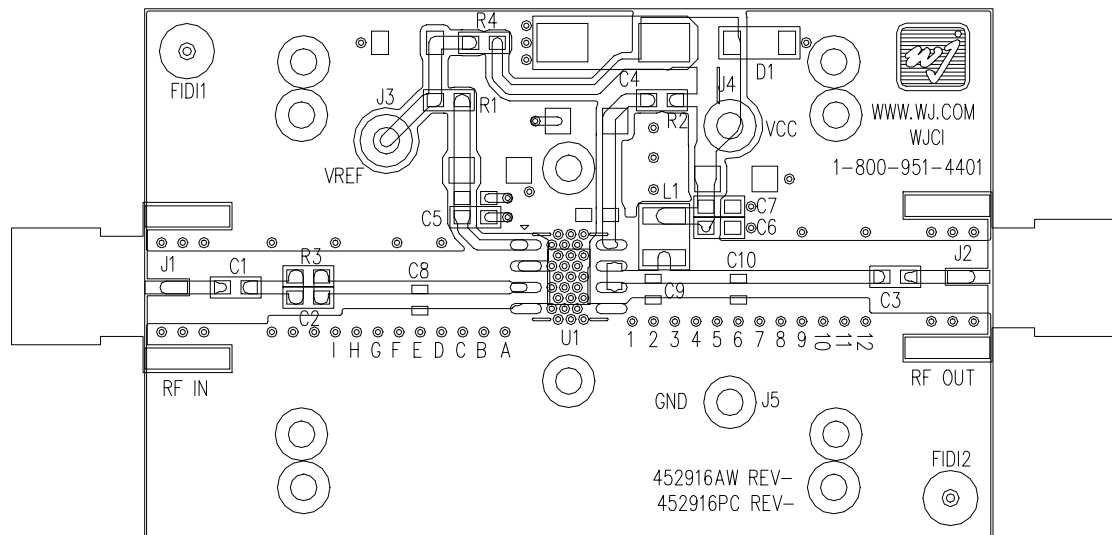

Circuit Board Material: .014" FR-4, 4 layers (others added for rigidity), .062" total thickness, 1 oz copper

This document contains information on a new product. Specifications and information are subject to change without notice



# AH215

## 1 Watt, High Gain HBT Amplifier

The Communications Edge™

Preliminary Product Information

### Outline Drawing

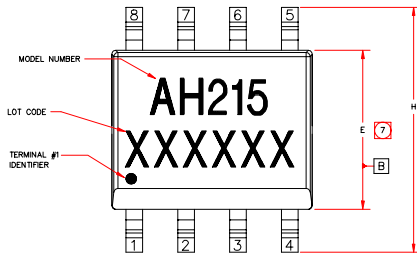

- NOTES:
- EXCEPT WHERE NOTED, THIS PART OUTLINE CONFORMS TO JEDEC STANDARD MS-012, ISSUE C FOR SMALL OUTLINE (SO) PERIPHERAL TERMINALS 3.75mm BODY WIDTH (PLASTIC).
  - DIMENSIONING & TOLERANCING CONFORM TO ASME Y14.4M-1994.
  - ALL DIMENSIONS ARE IN MILLIMETERS. ANGLES ARE IN DEGREES.
  - DOES NOT INCLUDE MOLD FLASH, PROTRUSIONS OR GATE BURRS, WHICH SHALL NOT EXCEED .15mm(.006in) PER SIDE.
  - DEVIATION FROM JEDEC MS-012 STANDARD.
  - LENGTH OF TERMINAL FOR SOLDERING TO A SUBSTRATE.
  - DOES NOT INCLUDE INTER-LEAD FLASH OR PROTRUSIONS, WHICH SHALL NOT EXCEED .25mm(.010in) PER SIDE.

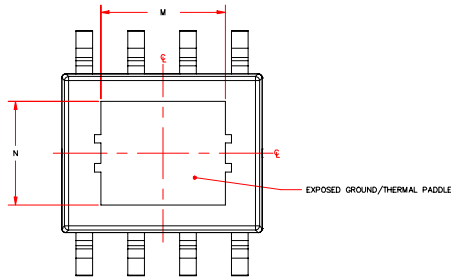
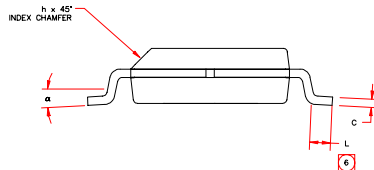
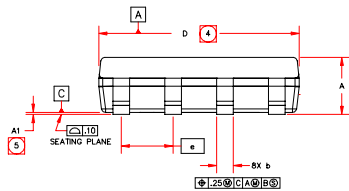

### Land Pattern

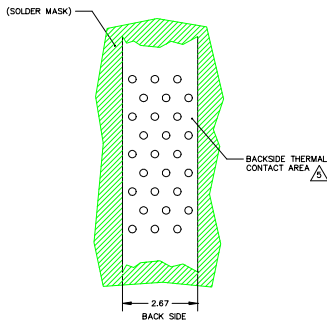
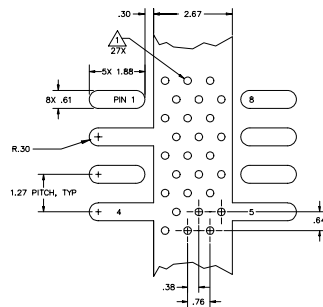
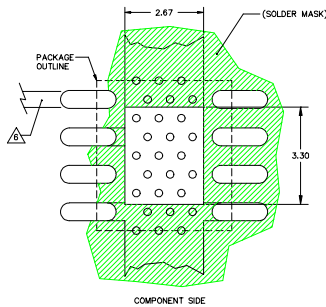

### Product Marking

The component will be marked with an "AH215" designator with a four- or five-digit alphanumeric lot code on the top surface of the package. Tape and reel specifications for this part is located on the website in the "Application Notes" section.

SYMBOL	MILLIMETERS		INCHES	
	MIN.	MAX.	MIN.	MAX.
A	1.30	1.50	.051	.059
A1	0	.10	0	.004
b	.38	.43	.015	.017
C	.18	.23	.007	.009
D	4.80	5.00	.189	.197
E	3.80	4.00	.150	.157
e	1.27 BSC		.050 BSC	
H	5.80	6.20	.228	.244
h	.25	.50	.01	.02
L	.40	1.27	.016	.050
M	2.95	3.15	.116	.124
N	2.03	2.54	.080	.100
$\alpha$	0	8°	0	8°

### ESD / MSL Information

ESD Classification: Class 1B  
 Value: Passes at 1000V  
 Test: Human Body Model (HBM)  
 Standard: JEDEC Standard JESD22-A114

MSL Rating: Level 2  
 Standard: JEDEC Standard J-STD-020A



Caution! ESD sensitive device.

### Mounting Config. Notes

- Ground / thermal vias are critical for the proper performance of this device. Vias should use a .35mm (#80 / .0135") diameter drill and have a final plated thru diameter of .25 mm (.010").
- Add as much copper as possible to inner and outer layers near the part to ensure optimal thermal performance.
- Mounting screws can be added near the part to fasten the board to a heatsink. Ensure that the ground / thermal via region contacts the heatsink.
- Do not put solder mask on the backside of the PC board in the region where the board contacts the heatsink.
- RF trace width depends upon the PC board material and construction.
- Use 1 oz. Copper minimum.
- All dimensions are in millimeters (inches). Angles are in degrees.

This document contains information on a new product. Specifications and information are subject to change without notice.



# AH215

1 Watt, High Gain HBT Amplifier

The Communications Edge™

Preliminary Product Information

## Typical Device Data

S-Parameters ( $V_D = +5\text{ V}$ ,  $I_D = 450\text{ mA}$ ,  $T = 25^\circ\text{C}$ , calibrated to device leads)

Freq (MHz)	S11 (dB)	S11 (ang)	S21 (dB)	S21 (ang)	S12 (dB)	S12 (ang)	S22 (dB)	S22 (ang)
50	-1.23	-177.95	24.07	122.55	-40.25	17.32	-1.26	-130.4
100	-1.01	178.17	19.55	116.55	-39.49	10.638	-1.33	-155.43
200	-1.01	172.63	15.55	112.97	-40.13	15.982	-1.17	-169.92
300	-1.04	167.77	13.65	105.3	-38.94	5.7863	-0.96	-176.59
400	-1.03	163.72	12.03	98.687	-38.83	10.314	-0.93	179.61
500	-1.12	159.38	10.78	93.155	-38.08	5.3245	-0.74	176.72
600	-1.21	155.20	9.86	85.809	-39.30	-4.2498	-0.66	173.43
700	-1.22	150.65	8.95	79.254	-38.32	-0.13729	-0.83	170.59
800	-1.34	146.17	8.11	73.185	-37.70	-2.3982	-0.83	168.67
900	-1.46	141.44	7.45	67.322	-37.76	-7.2837	-0.92	167.9
1000	-1.52	136.69	6.92	61.434	-37.73	-16.271	-0.95	166.34
1100	-1.72	131.79	6.51	55.865	-37.71	-11.359	-0.99	165.79
1200	-2.00	126.65	6.13	49.608	-37.14	-14.347	-1.05	165.13
1300	-2.25	120.62	6.03	43.944	-36.51	-25.971	-1.00	165.44
1400	-2.65	115.04	5.80	37.559	-36.23	-28.508	-1.04	164.55
1500	-3.12	104.06	5.99	29.52	-36.17	-39.163	-1.11	167.1
1600	-3.86	97.52	6.01	21.487	-36.45	-46.087	-1.11	166.24
1700	-4.98	91.41	6.12	11.812	-35.56	-55.849	-1.11	165.06
1800	-6.72	86.05	6.17	1.7006	-34.63	-68.996	-1.10	164.44
1900	-9.53	82.81	6.30	-10.239	-35.57	-85.848	-1.10	163.73
2000	-14.09	94.99	6.15	-23.839	-35.91	-100.68	-1.00	162.35
2100	-15.07	146.04	5.81	-38.398	-36.82	-127.06	-0.85	160.87
2200	-9.98	166.89	4.98	-52.921	-36.75	-147.66	-0.77	158.42
2300	-6.37	164.67	3.88	-67.574	-40.19	-173.37	-0.78	155.91
2400	-4.27	157.68	2.52	-80.088	-39.10	171.86	-0.79	154.12
2500	-2.98	150.26	1.06	-91.272	-37.90	150.57	-0.75	151.53
2600	-2.13	142.95	-0.42	-100.8	-37.80	123.26	-0.81	149.03
2700	-1.60	136.60	-1.93	-109.2	-38.74	106.15	-0.78	146.45
2800	-1.24	130.88	-3.40	-116.44	-38.58	89.558	-0.84	144.09
2900	-0.98	125.79	-4.75	-122.83	-37.76	77.861	-0.88	141.4
3000	-0.82	120.68	-6.09	-128.99	-39.37	67.22	-0.92	138.4

## Thermal Information

Parameters	Rating
Operating Case Temperature	-40 to +85 °C
Storage Temperature	-55 to +150 °C
Thermal Resistance	°C/W
. To ensure MTTF > 1x10e6 hrs	

This document contains information on a new product. Specifications and information are subject to change without notice.